

Fieldbus

Wiring Guide



Relcom Inc.



Fieldbus Wiring Guide

The purpose of this Fieldbus Wiring Guide is to provide information about the Fieldbus network so that its wiring system can be designed and installed for cost-effective and reliable operation.

There are many uses for Fieldbus and many ways it can be configured. It is not possible to give simple wiring rules that cover all cases. For this reason, this Guide will first explain how Fieldbus works so that the wiring system can be designed intelligently to achieve the best performance and most reliable operation with the lowest cost.

Fieldbus is defined in IEC standard 61158-2 : 3000. Detailed implementation requirements beyond the standard are available from the Fieldbus Foundation, an industry consortium that promotes Fieldbus technology. These more detailed specifications are needed so that devices made by different manufacturers are interoperable in a control system.

There is more to Fieldbus than the wiring. For those wanting information about how Fieldbus works to control a process, refer to:

Fieldbuses for Process Control; Jonas Burge, ISBN 1-55617-760-7

Foundation Fieldbus: A Pocket Guide; Ian Verhappen and Augusto Pereira; ISBN 1-55617-775-5.

Fieldbus Foundation
9005 Mountain Ridge Drive, Bowie Bldg, Suite 190
Austin, TX 78759-5316, USA
Tel: 512-794-8890

Relcom Inc.
2221 Yew Street
Forest Grove, OR 97116 USA
Tel: 503-357-5607
800-382-3765
Fax: 503-357-0491



Copyright and Intellectual Property Notices

Relcom Inc. believes the information it furnishes to be accurate and reliable. However, the specification and information disclosed in this document are delivered "AS IS" and all presentations or warranties, whether expressed or implied, including warranties or condition for fitness for a particular purpose, merchantability, accuracy and non-infringement. Relcom Inc. assumes no responsibility for the use of this information, nor any infringement of patents or other rights of third parties, which may result from its use. No license is granted by implication or otherwise under any patent, copyright, or other intellectual property right of Relcom Inc. except as specifically described herein. Relcom Inc. reserves the right to change specifications at any time without notice.

Relcom Inc. has intellectual property rights ("Relcom Inc. IPR") relating to implementations of the technology described in this publication ("the Technology"). In particular, and without limitation, Relcom Inc. IPR may include one or more patents or patent applications in the U.S. or other countries. Your limited right to use this publication does not grant you any right or license to Relcom Inc. IPR nor any right or license to implement the Technology. Relcom Inc. may, in its sole discretion, make available a limited license to Relcom Inc. IPR and/or to the Technology under a separate license agreement.

All rights reserved. No part of this manual may be reproduced, photocopied, stored on a retrieval system, or transmitted without the express prior consent of Relcom Inc. Copyright © 2004 Relcom Inc.

Relcom Inc. and the Relcom Inc. logo, are trademarks or registered trademarks of Relcom Inc. in the United States and other countries. All other trademarks and logos are the property of their respective owners.

Cover photo courtesy Texas Parks & Wildlife Dept. © 2004

Table of Contents

Chapter 1: Fieldbus Network Concept	1
Conventional DCS.....	1
Fieldbus	2
Wiring Diagram Convention	2
Chapter 2: Fieldbus Configuration	3
Common Fieldbus Configuration.....	3
Star Configuration.....	4
Chapter 3: Signals	5
Fieldbus Signal.....	5
Manchester Code Signal.....	6
Preamble.....	6
Start and End Delimiters.....	7
Fieldbus Frame	7
Multiple Fieldbus Frames.....	8
Chapter 4: Fieldbus Cable	9
Fieldbus Cable Characteristics	9
Chapter 5: Terminator	11
Terminator Examples.....	11
Chapter 6: Wire Connections	13
Terminal Strip Wiring.....	13
Wiring Block	14
Wiring Block with Current Limiters	16
Chapter 7: Fieldbus Power	17
Power Conditioner.....	17
Voltage.....	17
Current.....	17

Galvanic Isolation	18
Chapter 8: Fieldbus Limitations	19
Power Distribution	19
Attenuation	20
Transmitted and Received Signals.....	21
Chapter 9: Reliability Considerations	23
DCS Control System.....	23
Fieldbus System	24
Spur Shorts	24
Spur Short Circuit Protection with Active Current Limit	25
Trunk Cable Failures	25
Power Supply Failure.....	25
Redundant Power Conditioner Alarming	26
Redundant Fieldbus Power Conditioner Mean Time to Failure	26
Lightning Surges	28
Chapter 10: Isolation and Segment Independence	29
Galvanic Isolation	29
Differential Voltage and Common Mode Voltage	29
Current Limiter Bypass	30
Bypassing the Current Limiter.....	30
Crosstalk	31
Multiple Wiring Errors	31
Common Isolator and Two Power Conditioners.....	31
Individual Isolation	32
Chapter 11: Fieldbus Cable Selection and Installation for Process Plants	33
Cable Types	33
Cable Support	35
Fieldbus Cable	35
Installation Considerations.....	36
Summary.....	39

References.....	40
Chapter 12: Hazardous Area Power and Repeaters	41
Repeaters with FISCO Power Supplies.....	42
Chapter 13: Current Limiters for Nonincendive Protection	43
Chapter 14: Earthing/Grounding Guidelines	45
FOUNDATION™ Fieldbus Requirements	45
Hazardous Area Considerations	45
Practical Arrangements – Single Point Grounding.....	46
Practical Arrangements – Capacitive Grounding	47
Practical Arrangements – Equipotential Grounding	47
Chapter 15: Glossary	49
Further Information	51
MTL Application Notes.....	51
MTL Contacts.....	51

Chapter 1

Fieldbus Network Concept

Summary: Fieldbus is a Local Area Network for process control that uses shared wiring for powering devices and carrying signals between devices.

In a conventional **Distributed Control System (DCS)**, two wires are used to connect to a device. The devices may be instruments for measuring temperature or pressure. Devices can also be actuators such as valves. The wires carry electrical power to a device. The device signals its measured value to the DCS's controller by varying the current it uses between 4 and 20 milliAmps (mAmps). The controller gathers the data from a number of devices, makes the necessary calculations and sends commands by varying the current to the actuator. For example, 4 mAmps may mean that the valve is totally closed and 20 mAmps may mean the valve is fully open.

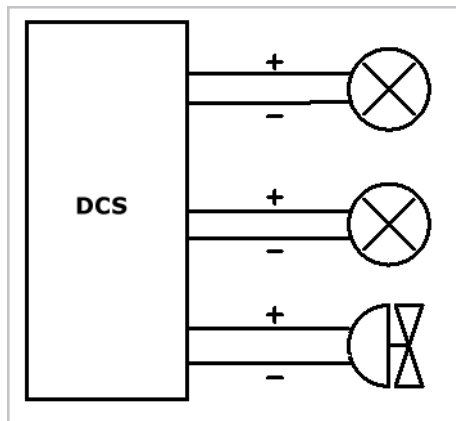

Figure 1.1: Conventional DCS

Fieldbus also uses two wires to carry power to the devices. A number of devices share the same Fieldbus wires. Fieldbus devices vary the voltage on the two wires to send signals. See "*Signals*" on page 5. The signal is digital.

Because devices share the wires, the devices can send data to each other without a DCS controller. Fieldbus data transmissions have more information than just a single variable about temperature, pressure, or valve position. From the data that are shared between the devices, the devices can determine how to control the process. The host device only supervises the operation. Fieldbus is a **local area network (LAN)** for process control.

Fieldbus Network Concept

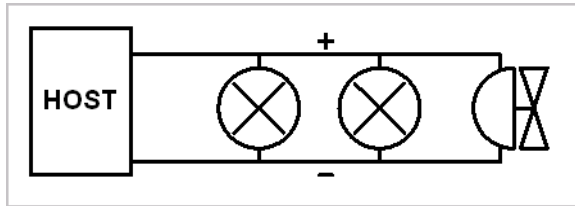

Figure 1.2: Fieldbus

The two wires are a twisted pair similar to the usual 4-20 mA wiring used for conventional devices. For more information, refer to *"Wire Connections"* on page 13.

For the sake of simplicity of wiring diagrams, the wires are shown as a single line.

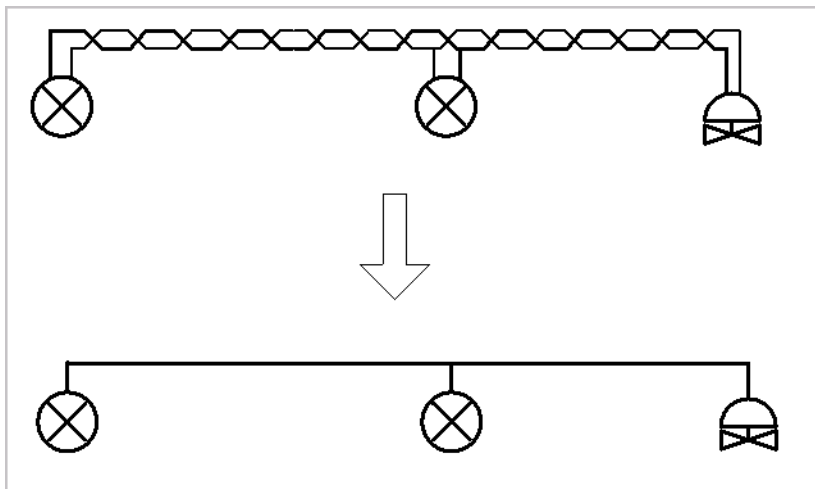

Figure 1.3: Wiring Diagram Convention

Chapter 2

Fieldbus Configuration

Summary: Fieldbus network's shared wiring carries power to devices and signals between devices. Two terminators are required. A power supply and a power conditioner are needed to provide Fieldbus power.

Fieldbus is a process control local area network used for interconnecting sensors, actuators, and control devices. A common type of Fieldbus configuration is shown below.

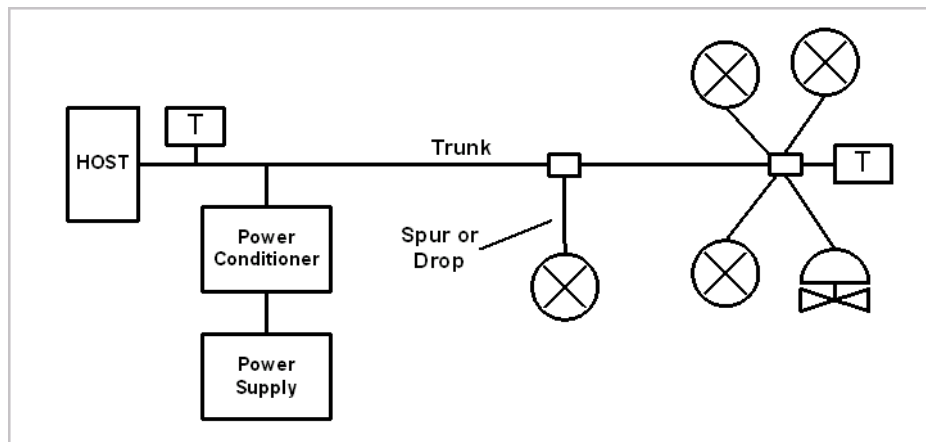

Figure 2.1: Common Fieldbus Configuration

A twisted-pair **trunk** cable connects control room equipment with a number of devices in the field, for example, sensors such as a temperature or pressure transducers and actuators such as valve positioners. The field devices can be connected with **spur** or **drop** cables to a common terminal block, called the **chickenfoot**, in a junction box. Devices can also be connected along the trunk cable with spurs.

A **terminator** (T) is required at each end of the Fieldbus cable to avoid distorting signals and allow the twisted-pair cable to carry digital signals.

Power to the devices is provided by a power supply through a **power conditioner** (PC). The power conditioner is needed to separate a conventional power supply from the Fieldbus wiring so that the signals are not absorbed by the power supply.

Fieldbus Configuration

A host or H1 device is usually located in the control room. Its function is to oversee the operation of the control system made up of devices connected by the Fieldbus network.

For control systems that are limited in size, all the wiring components, the power conditioner and terminators can be in a single wiring block to form a star configuration.

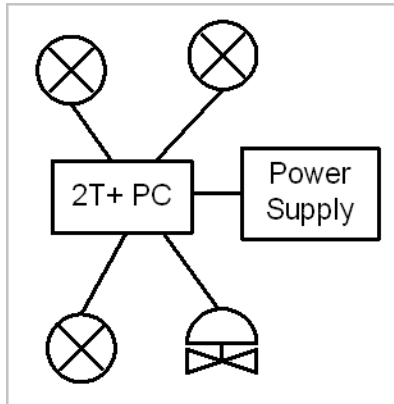

Figure 2.2: Star Configuration

The diagrams above show only two of the many possible Fieldbus configurations. The power supply and conditioner could be in the field or on a marshalling panel. The control device could be in the field with only a display device in the control room. All these configurations are possible so long as the basic signal transmission and power distribution capabilities are provided: a twisted-pair cable, two terminators, and a conditioned power supply.

Generally, there are less than 16 devices on any single Fieldbus **segment**, a single network. In a large process plant there may be several hundred segments. From a power and signal point of view, each of the segments is a separate network. The segments are linked together in an overall control system by other means that are beyond the scope of this Guide.

Chapter 3

Signals

Summary: Devices signal each other by varying the current they draw from the network. The signal is Manchester coded. The LAS arbitrates which device can use the network for signaling.

The twisted pair cables, terminators, and the power conditioner work together as a wiring system that can carry signals between Fieldbus devices. When a device is enabled to signal (See "LAS" on page 8), it varies the amount of current it draws from the network.

When not transmitting, a device draws power from the cable for its internal operation. It also draws an additional 10 mAmps that it "wastes." When the device transmits a high signal, it turns off this extra 10 mAmps. This increases the voltage between the wires. When the device transmits a low signal, it draws an extra 10 mAmps from the wires, resulting in a voltage decrease. The signal waveform is shown below. Note that the signal is above and below the 24-volt non-transmitting level on the network.

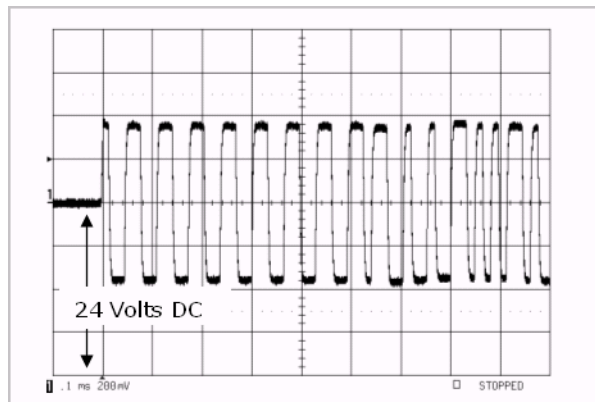

Figure 3.1: Fieldbus Signal

Digital data is sent on the Fieldbus at a rate of 31.25 kbits/second. Thus, each bit cell is 32 microseconds long. The digital data, ones and zeros, is represented as a Manchester code. A zero is a positive signal transition in the middle of a bit cell; a one is a negative transition in the middle of a bit cell.

A sequence of Manchester encoded ones and zeros would look like this:

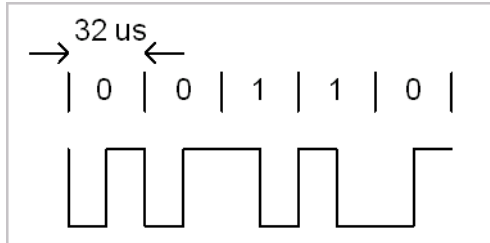

Figure 3.2: Manchester Code Signal

When a device begins transmitting, it puts out a **preamble**, an 8-bit sequence with alternating ones and zeros.

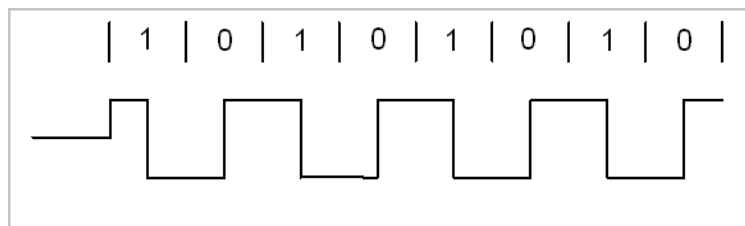

Figure 3.3: Preamble

This pattern is used by the receiving devices to synchronize themselves to bit cell boundaries.

Besides ones and zeros, there are also two non-data symbols. These non-data symbols are N+, a high level during the whole bit cell, and N-, a low level during the whole bit cell. These symbols are used to make an 8-bit **start delimiter** that shows where real data starts and an 8-bit **end delimiter** that shows where data transmission stops.

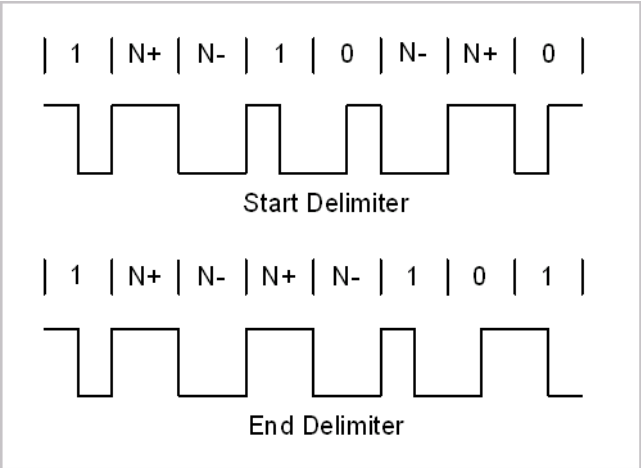

Figure 3.4: Start and End Delimiters

When a device transmits, the different parts are combined to form a data frame:

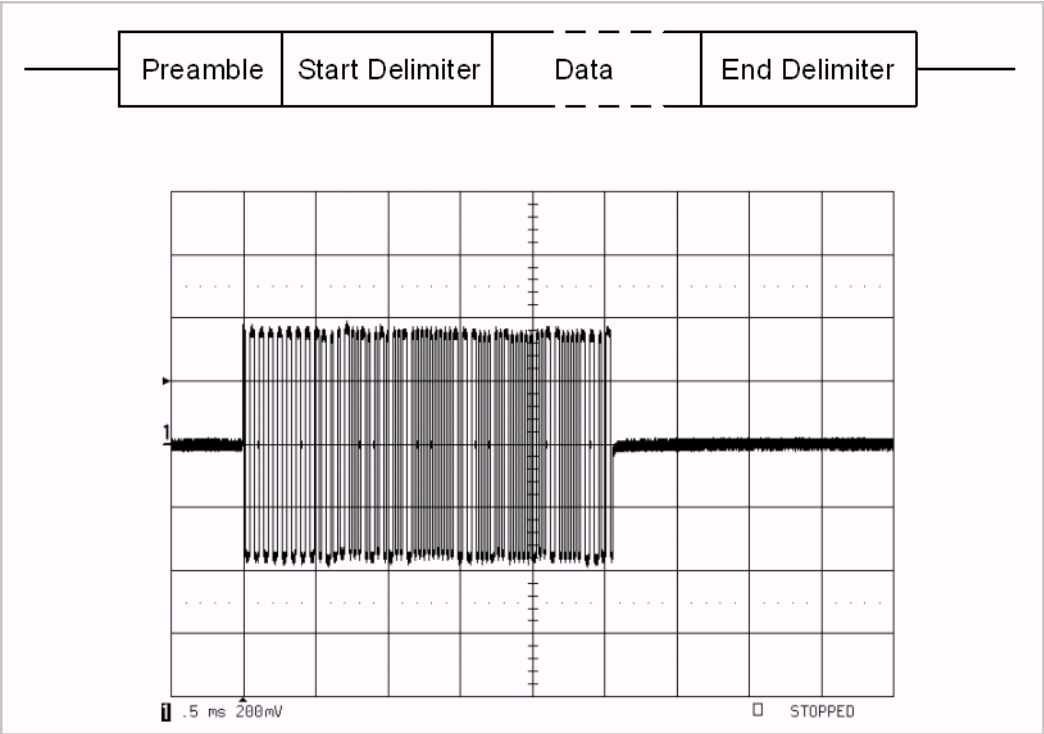

Figure 3.5: Fieldbus Frame

Signals

The Data portion of the frame contains information such as the address of the device for which the frame is intended, identification of the type of frame, measurement values, etc. The Data portion of a frame can be up to 266 bytes long.

The delimiters are very different from any signal pattern that might be in the Data portion of the frame. This difference allows the Data portion of the frame to be unambiguously identified and allows Data corrupted by noise to be detected using a **Frame Check Sequence (FCS)**. The FCS is the very last part of the Data portion of the frame. This feature makes Fieldbus much more robust than many other control networks.

Because all devices share the cable, only one device should transmit at any given time. Otherwise, there would be chaos on the cable with all the transmitted signals interfering with one another. A special device, called the **Link Active Scheduler (LAS)**, selects which single device can transmit. The LAS allows each device to transmit by sending out a special frame to each device in turn. A frame might be: the LAS asking a device to transmit data, a device broadcasting its data to other devices, a device reporting an error condition, etc. If an oscilloscope were used to observe the signals on the Fieldbus, the display would show frames with gaps of silence between them, as shown below:

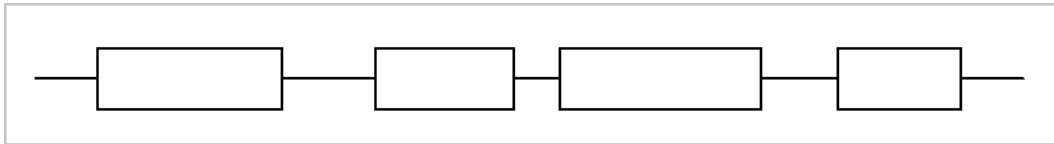

Figure 3.6: Multiple Fieldbus Frames

How Fieldbus is used for conveying specific types of process information is beyond the scope of this Guide.

Chapter 4

Fieldbus Cable

Summary: Fieldbus uses shielded, twisted-pair cable. The shield is grounded at only one place.

Fieldbus uses twisted-pair wires. A twisted-pair is used, rather than a pair of parallel wires, to reduce external noise from getting onto the wires. A shield over the twisted-pair further reduces noise. The twisted-pair wires, the shield and their covering jacket are called a cable.

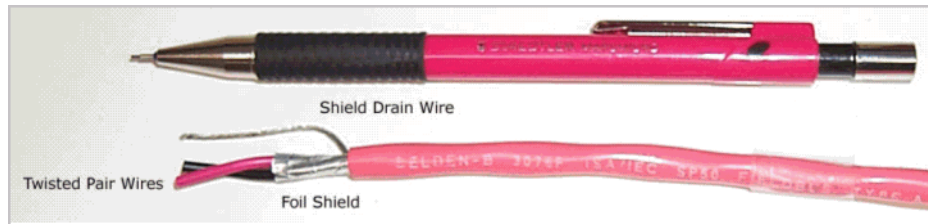

Figure 4.1: Fieldbus Cable (Pen shown for size comparison)

For new installations or to get maximum performance from Fieldbus, the cable should have the following characteristics

Table 1: Fieldbus Cable Characteristics

Wire size (minimum)	18 AWG (0.8 mm)
Shield	90% coverage
Attenuation	3 dB/km at 39 kHz
Characteristic Impedance	100 Ohms +/-20% at 31.25 kHz

Fieldbus signaling is very robust so that ordinary instrumentation cable can be used, such as single or multi-pair used for 4-20 mA devices. If possible, to avoid confusion, the wire insulation colors should match the color convention of existing wiring in the plant. If new cable is installed, the suggested convention is orange for the (+) wire and blue for the (-).

The shield is continuous throughout the network. The shield is connected to ground at only one place, usually at the power supply. The shield is not

Fieldbus Cable

connected to ground at the devices or any other place. There may be regulatory requirements for cable jacketing, such as armor, depending where the cable is used.

Chapter 5

Terminator

Summary: A terminator is needed at each end of the Fieldbus network segment.

Two terminators are required on each Fieldbus network segment. Generally, one terminator is at the control room end of the cable and the other terminator is in the junction box in the field.

The terminator can be a separate part or may be part of a wiring block or part of a Fieldbus power supply. The terminator should be clearly marked so that it can be identified in an installed system.

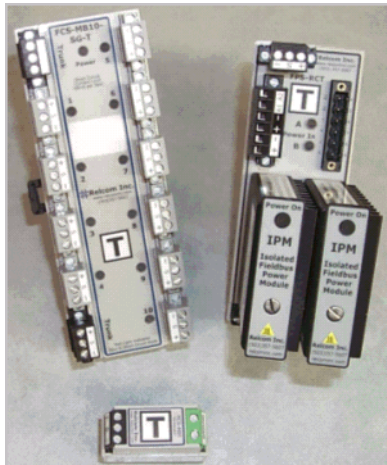

Figure 5.1: Terminator Examples

A Fieldbus network without two terminators will not have the proper signals. A network with only one terminator may appear to function properly, but will have distorted signals with increased amplitude and greater susceptibility to signal reflection noise. (A signal traveling on the cable and reaching the end of the cable without a terminator will reflect and travel back in the opposite direction).

A network with three or more terminators will have decreased signal amplitude to the point where devices may lose the ability to communicate with one another.

Chapter 6

Wire Connections

Summary: Fieldbus wiring blocks make wiring easier, more reliable, and provide additional features.

Fieldbus cable sections, the trunk cable, and the drop cables, need to be connected together. This could be done using terminal strips. For example, to connect a device spur to the trunk cable, the following connections would have to be made, as shown below.

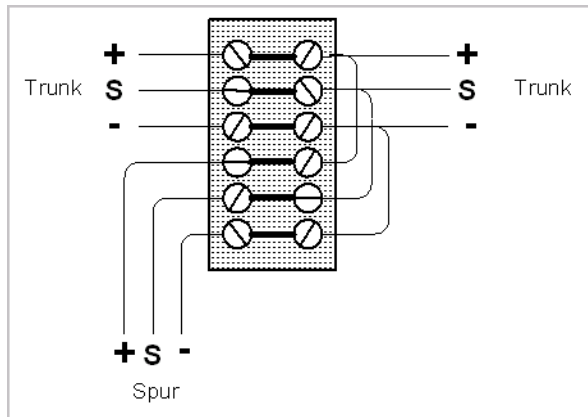

Figure 6.1: Terminal Strip Wiring

While this can work, there are potential problems. Two wires have to be put under the same screw. Also, it is easy to get the jumper wires mixed up.

An easier and more reliable connection method is to use wiring blocks made for Fieldbus. These blocks have internal connections between corresponding wire terminals.

Wire Connections

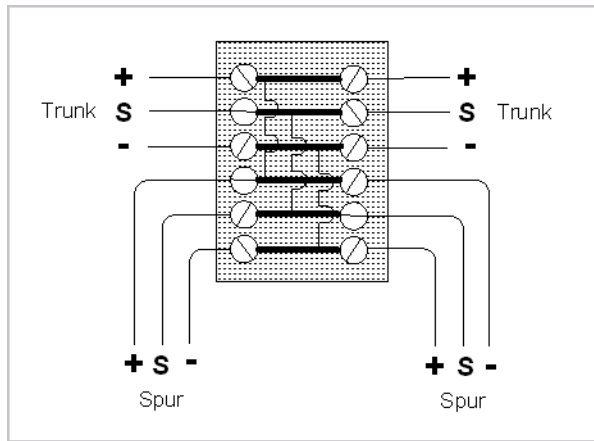

Figure 6.2: Wiring Block

There are several ways to terminate cable to the wiring block: screw terminals, pluggable screw terminals and spring clamps. At the time of this writing, the most popular method is the pluggable screw terminal.



Figure 6.3a shows a photograph of two wiring blocks and a terminator in a junction box. The black connectors are for the trunk cable.

Figure 6.3a: Wiring Block Example

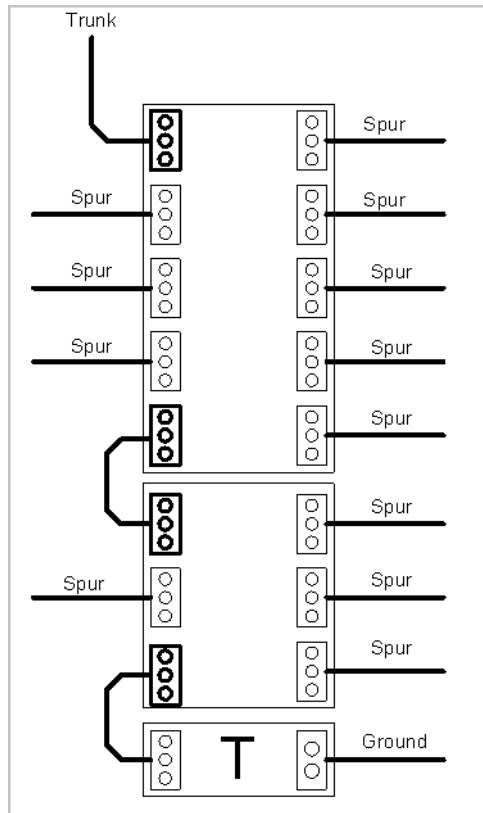

Figure 6.3b shows this arrangement schematically. The trunk cable is attached to the upper left-hand terminal of the 8-drop wiring block. The other end of the 8-way wiring block is connected to the 4-way wiring block with a short jumper cable. The other end of the 4-way wiring block is connected to the terminator, (T).

Figure 6.3b: Wiring Block Example

This example shows how 12 Fieldbus devices are interconnected in a junction box. If the two wiring blocks had been in two separate junction boxes, the jumper cable would simply be a longer cable between the junction boxes.

Using pluggable screw terminals, the cable can be prepared and attached to the plug without reaching into the often tight spaces of a junction box. The plug is then inserted into the wiring block and fastened so that it does not vibrate out or become disconnected if cables are moved.

Wiring blocks have additional features, such as a DIN-rail mounting clip and an indicator light that shows if Fieldbus power is on at the wiring block. The biggest benefit of wiring blocks is that they can have current limiters built into them, which prevents a short on the spur connection from bringing down the entire network segment.

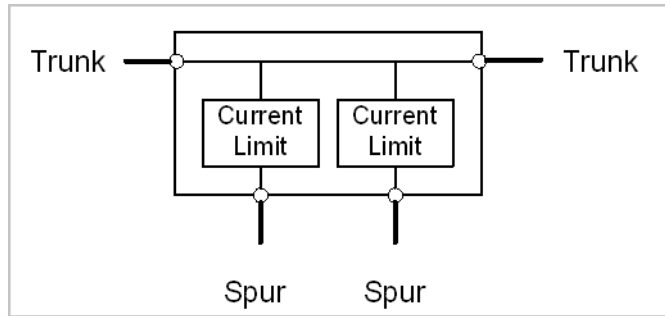

Figure 6.4: Wiring Block with Current Limiters

If a device or the drop cable is shorted, the current is limited. The particular device on the spur does not function, but the devices on the rest of the Fieldbus network continue to work. For troubleshooting purposes, the wiring block has an indicator light that shows the shorted spur. For more information, refer to *“Reliability Considerations”* on page 23.

Chapter 7

Fieldbus Power

Summary: A power conditioner is needed between a power supply and the Fieldbus wires to power a Fieldbus.

An ordinary constant voltage power supply cannot be used directly to power a Fieldbus. A **power conditioner (PC)** needs to be used to provide a filter between the network and the power source so that the signals on the network do not get absorbed by the power source.

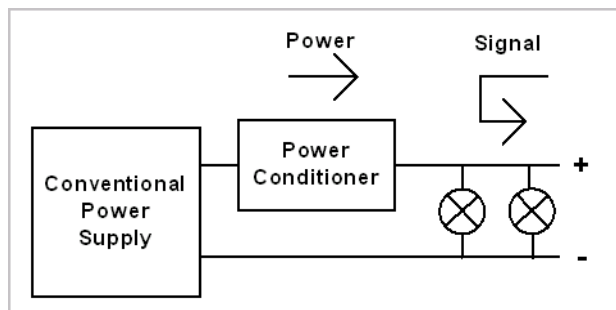

Figure 7.1: Power Conditioner

A Fieldbus power supply with its power conditioner has a number of requirements, as listed below.

Voltage

The voltage needs to be between 9 and 32 Volts. Generally, Fieldbus power supplies provide about 24 Volts. See *"Fieldbus Limitations"* on page 19.

Current

A typical Fieldbus device uses about 20 mAmps of current. Generally, the number of devices on a Fieldbus network segment is less than 16. A power supply with a $16 \times 20 = 320$ mAmp current rating is sufficient for most applications.

Galvanic Isolation

The power supply and power conditioner combination needs to be electrically isolated from grounds. This means that bulk 24 V DC power supplies that have one output grounded cannot be used with power conditioners if they do not themselves provide electrical isolation. Galvanic isolation is important in minimizing noise ingress and providing network reliability.

There are a number of other power supply requirements such as noise, short circuit recovery, segment crosstalk, etc. These requirements will be defined in the upcoming Foundation Fieldbus power supply test specification FF-641.

Fieldbus network operation is totally dependent on the power supply. If the power supply or the power conditioner fails, power to the entire network segment and the process it controls is lost. For control systems that require high availability, redundant Fieldbus power supplies are used. For more information, refer to "*Power Supply Failure*" on page 25.

If Fieldbus is used in hazardous areas, additional requirements are placed on the power supplies.

Chapter 8

Fieldbus Limitations

Summary: Power distribution, attenuation, and signal distortion limit the size of a Fieldbus network segment and the number of devices that can be interconnected.

Power Distribution

The number of devices that can be on a Fieldbus segment is limited by the power supply voltage, the resistance of the cable, and the amount of current drawn by the devices. The following example shows how to calculate the maximum number of devices that can be attached at the chickenfoot.

- The Fieldbus power supply output is 20 Volts to the network.
- The cable used is 18 gauge and has a resistance of 22 Ohms/km for each conductor. The trunk cable is 1 km long. The combined resistance of both wires is 44 Ohms.
- Each device at the chickenfoot draws 20 mAmps.

Since the minimum voltage needed by a device is 9 Volts, there are $20 - 9 = 11$ Volts that are available to be used by the cable resistance. The total current that can be supplied at the chickenfoot is:

$$\text{Voltage} / \text{Resistance} = \text{Current available}$$

$$11 \text{ Volts} / 44 \text{ Ohms/km} = 250 \text{ mAmps}$$

Since each device draws 20 mAmps, the maximum number of devices at the chickenfoot of this example is:

$$\text{Current available} / \text{Device draw} = \text{Number of devices}$$

$$250 \text{ mAmps} / 20 \text{ mAmps} = 12 \text{ devices}$$

When devices are attached to the cable at different places, the power distribution calculation becomes more involved. Generally, the cable length is much shorter than 1 km and the Fieldbus power supply voltage is higher so that power distribution is not a big issue.

Attenuation

As signals travel on a Fieldbus cable, they are attenuated, that is, they are reduced in amplitude. The longer the cable, the greater the attenuation. The Fieldbus standard requires that a Fieldbus device transmits a signal at least 0.75 Volts peak-to-peak and that a receiver must be able to detect a signal of as little as 0.15 Volts peak-to-peak. (In electrical engineering talk, this is 14 dB of attenuation). If standard Fieldbus cable is used (attenuation of 3 dB/ km), then the cable can be

$$14 \text{ dB} / 3 \text{ dB/km} = 4.6 \text{ km long.}$$

However, there is additional attenuation that needs to be considered. Signals are also attenuated by the spur cables that branch off the trunk cable. This attenuation is largely caused by cable capacitance. Standard Fieldbus cable capacitance is about 0.15 nF/meter and the attenuation caused by capacitance is about 0.035 dB/nF. As an example, if the lengths of all the spurs is 500 meters, then the attenuation will be

$$500 \text{ meters} \times 0.15 \text{ nF/meter} \times 0.035 \text{ dB/nF} = 2.6 \text{ dB.}$$

As an example, assume that the trunk cable is 800 meters long. The trunk attenuation is

$$3 \text{ dB/ km} \times 0.8 \text{ km} = 2.4 \text{ dB.}$$

The total signal attenuation is

$$2.6 \text{ dB} + 2.4 \text{ dB} = 5 \text{ dB.}$$

This is well within the 14 dB available.

Signal Distortion

Fieldbus cable is limited to less than the theoretically possible length. Signals also get distorted by various cable characteristics, spur reflections, etc. Shown below on the left is a transmitted signal and on the right a received signal at the end of a 900 meter long cable with 16 120-meter spurs at the chickenfoot.

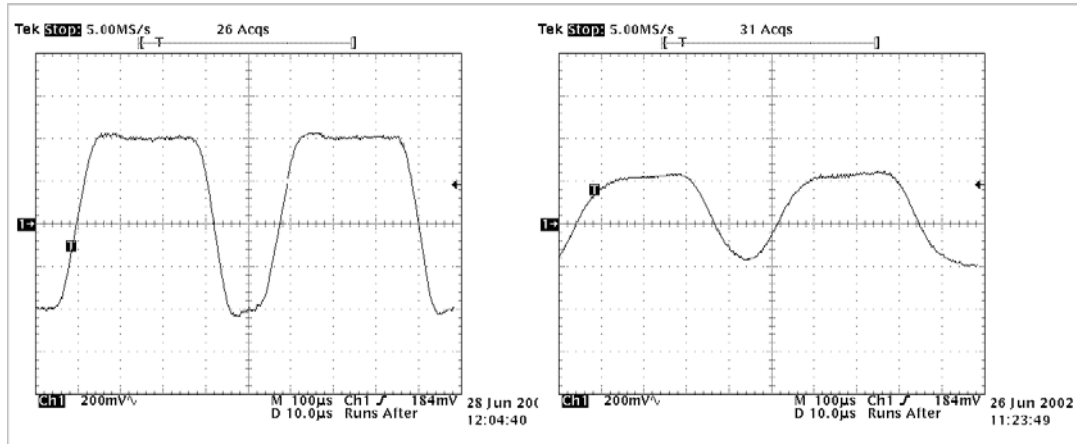

Figure 8.1: Transmitted and Received Signals

Although it is not possible here to provide a definitive analysis of cable distortion, here are two recommendations to minimize distortion:

- If the trunk cable is more than 250 meters long, put a terminator on each end.
- Keep each spur length below 120 meters.

These recommendations are a result of testing Fieldbus signal fidelity on a 1 km long trunk cable with 16 spurs 120-meter long at the chickenfoot.

Chapter 9

Reliability Considerations

Summary: Since Fieldbus uses shared wiring, reliability precautions need to be taken for networks used in critical applications. Reliability enhancement includes short circuit protectors on spur cables, protected trunk cable, redundant power supplies and lightning surge protectors.

Before the advent of Fieldbus, distributed control systems, DCS, had individual instruments and actuators each connected by a separate pair of wires to a control unit in the control room. The standard communication method uses a 4 to 20 mA current to represent a value such as a pressure measurement. The wires also carry power to the instrument or actuator.

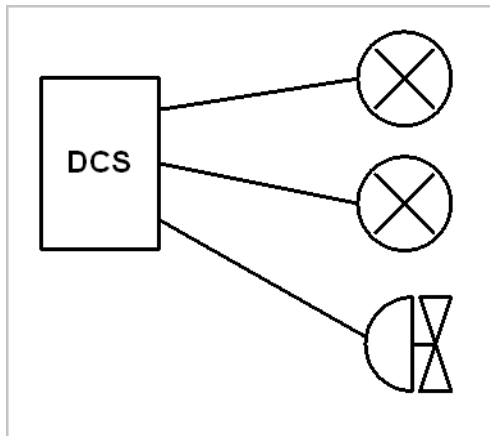

Figure 9.1: DCS Control System

In traditional control, if one of the instruments or its cable failed, the control system would be missing only that one instrument. The vulnerability was the shared controller. If the controller failed, control was lost.

Fieldbus is different. The host in the control room may not be running the process but only monitoring it. The task of running the process may be assigned to a valve and possibly another field device as a backup in case the primary controller fails.

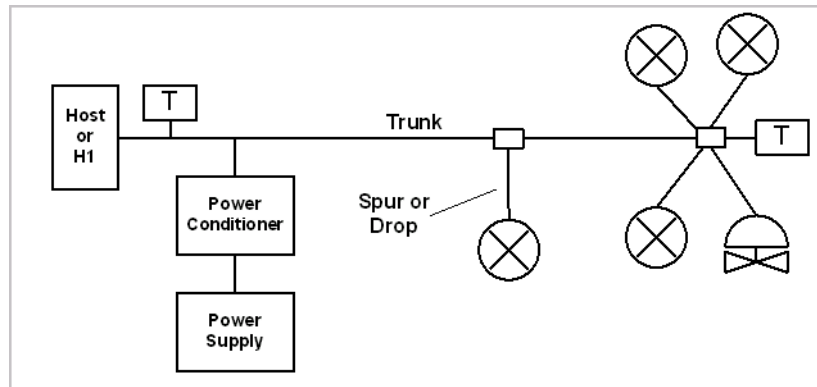

Figure 9.2: Fieldbus System

At first sight, it appears that Fieldbus is more robust. Control is distributed and runs in the field without a central DCS. There are, however, new vulnerabilities to consider. In Fieldbus-based systems, the shared wiring and the power supply are the critical resources because all the devices share the same cable and power supply. If these fail, then the whole network is inoperative. There are four main Fieldbus reliability issues:

- Spur short circuits
- Trunk failures
- Power supply failures
- Surges

Spur Shorts

Since Fieldbus wiring is shared, a short circuit in one of the devices or in its spur cable disables the segment and hence the whole process that depends on it. This can happen when a new instrument is installed, an instrument is serviced or the device becomes waterlogged.

This potential problem can be overcome by using a current limiter between the trunk cable and the spur cable. These are built into a wiring block in the junction box at the chickenfoot. The current limiter only allows a given amount of current to be used by each device. If a spur is shorted, the current will be limited within a few microseconds. Only the shorted device is affected and the rest of the devices continue to operate.

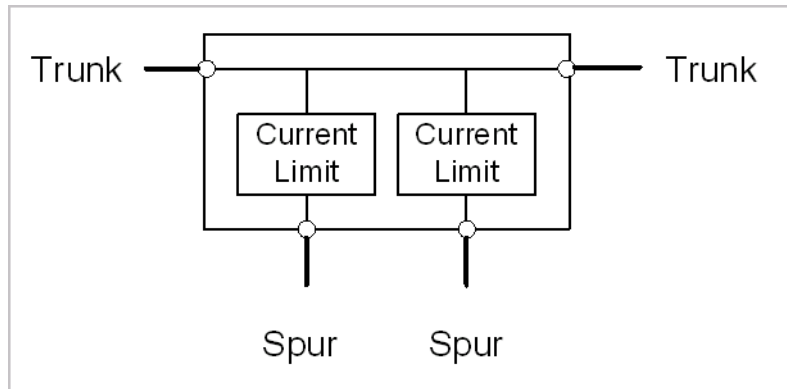

Figure 9.3: Spur Short Circuit Protection with Active Current Limit

Trunk Cable Failures

Another vulnerability of the system is the trunk cable. If it is cut, then the power to the field is lost. While this is true, trunk cable vulnerability is something that is also a problem in traditional DCS systems. In Figure 9.1, “DCS Control System” on page 23, the wires are shown schematically as going between individual instruments and the controller. In reality, a single cable carries the multiple instrument wire pairs. If the cable is cut, it is not just a single instrument that is lost but many or all.

In the end, if system reliability is a concern, the trunk cable needs to be protected in a conduit or a sturdy cable tray.

Power Supply Failure

If Fieldbus segment power fails, then the entire Fieldbus segment is down and control is lost. Redundant power supplies make this problem vanishingly small.

The component parts of a redundant Fieldbus power supply are shown below. The Fieldbus power supply’s input comes from two battery-backed bulk power supplies that provide 24 V power to various other pieces of equipment in the control room. The input 24 V power feeds two independent power isolators and conditioners. The outputs of the two isolators and conditioners are combined to feed the Fieldbus segment.

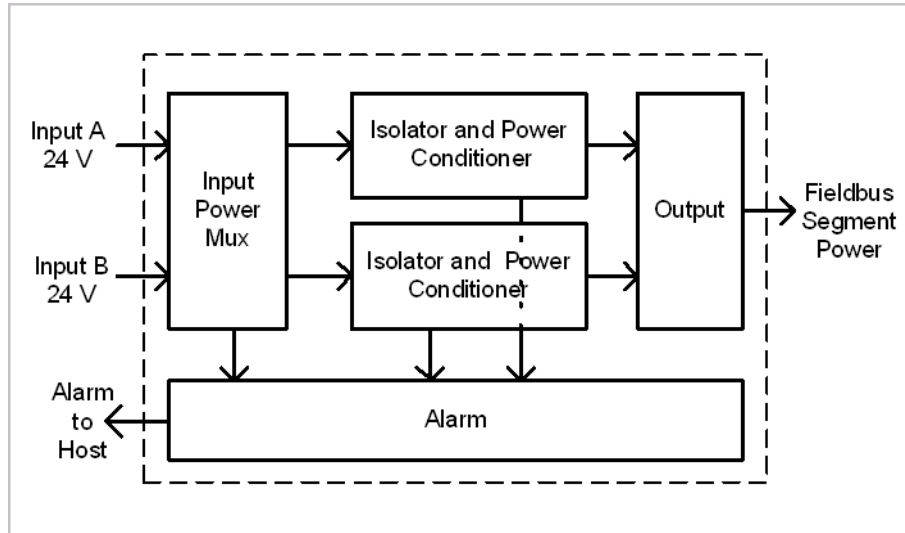

Figure 9.4: Redundant Power Conditioner Alarming

Redundancy is not enough. There must be alarming. Without alarming, if one of the bulk input power supplies or a redundant Fieldbus power supply fails, the system continues to operate until there is a second failure. The alarming shown above monitors the input power, each of the isolators and the associated power conditioners. The alarm itself can be a simple normally-closed relay contact. This relay is connected to the host and notifies the operator that there is a problem. Indicator lights on the redundant power supply show maintenance personnel which module of the supply is defective. The isolator and power conditioning modules can be hot-swapped with no disruption to the operation of the Fieldbus network.

The table below shows the Mean Time to Failure (MTTF) of the components of a redundant power supply.

Table 1: Redundant Fieldbus Power Conditioner Mean Time to Failure

Component	Mean Time To Failure
Isolator and conditioning module	54 years
Power supply backplane and alarming circuits leading to failure of Fieldbus segment	88000 years

A more useful figure for the control engineer is the Availability of a system. To calculate availability, we also need to know the Mean Time To Repair

(MTTR). The MTTR for a failure which raises an alarm is typically taken as 8 hours (1 shift) to cover the time taken to recognize the alarm, get the necessary authorizations to work on the system, collect a spare from stores and complete the replacement.

The Availability is
$$\frac{MTTF}{MTTF + MTTR}$$

To calculate the availability of the Fieldbus segment due to the power supply, we need to consider

- The MTTF of the isolator and power conditioning modules and
- The MTTF of the common components on the backplane whose failure would result in the failure of the Fieldbus segment.

With two power supply modules operating, the **Unavailability, (1 - Availability)**, of the redundant power supply is the probability of both modules being unavailable at the same time. This is calculated as the product of the individual power module unavailabilities.

The unavailability for the Fieldbus segment is based on

- Both the isolation and power conditioning modules failing at the same time or
- The common backplane components failing which affect segment availability

The unavailability of the Fieldbus segment is the sum of these two unavailabilities.

From this, the Availability for a Fieldbus segment with the redundant isolator and power conditioner system is 99.9999989%. This means that a Fieldbus system could be down due to redundant power supply failures on average for 0.3 seconds/year.

Lightning Surges

There is no protection against a direct lightning strike. The energy involved is too great. The struck device simply disintegrates.

Lightning strikes also have effects at great distances from the strike point. The voltage between earth points that are normally considered at the same potential become large. If a cable connects devices that are at some distance from each other, the ground potential difference can travel over the cable and break down the electrical isolation of Fieldbus devices. Since many Fieldbus devices share the same cable, a lightning surge can adversely affect all of them.

The general rule is that if the a horizontal distance between devices of greater than 100m or vertical separation greater than 10m, lightning surge protection should be used. Given that Fieldbus devices are unlikely to all be mounted within a few meters of each other, the voltage developed between any two devices could be large enough to breakdown insulation and produce damage.

Isolation and Segment Independence

Summary: A Fieldbus segment must be electrically (galvanically) isolated from ground and ideally should be galvanically isolated from other segments to make the network more reliable. A good Fieldbus power supply satisfies these requirements.

There are a number of ways to power a Fieldbus segment. Some ways work better than others. Consider the following information.

Galvanic Isolation

The Fieldbus standard requires that the power provided to a segment be galvanically isolated from ground. Galvanic isolation provides maximum noise immunity. If you speak electrical engineering, here is the reason for this requirement:

When a segment is galvanically isolated, the (+) and (-) voltages on the Fieldbus wires are relative to each other and are not referenced to a ground. For example, the voltage between the wires might be 24 Volts with respect to each other. This is called **Differential Voltage**. The digital signals on Fieldbus wires are differential. With respect to ground, the voltage on each wire may be, say +124 Volts for the (+) wire and 100 Volts for the (-) wire. The 100 Volts in this example is the **Common Mode Voltage**.

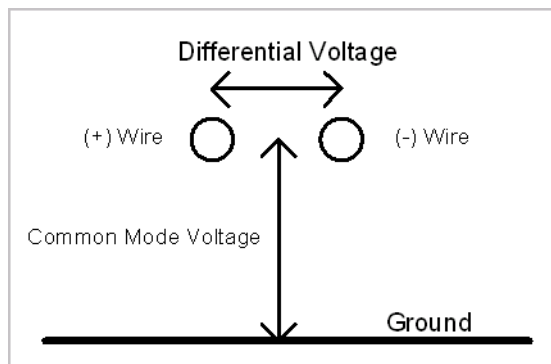

Figure 10.1: Differential Voltage and Common Mode Voltage

The devices attached to the Fieldbus wires only “see” differential voltage. The reason twisted pair wires are used for Fieldbus is that if noise gets on one wire, it also gets equally on the other wire. Thus, noise is a common

mode voltage. With galvanic isolation, there is no ground reference for the two Fieldbus signal wires to the grounded shield so that conversion of common mode noise to differential noise is minimized. If one of the Fieldbus wires were referenced to ground, the common mode noise on the wires would not be equal and differential noise would be created. (The cable shield's function is to further reduce noise by keeping common mode noise off the two wires).

Current Limiter Bypass

Galvanic isolation from ground also provides another benefit. Current limiters are used between the network's trunk and the drop cable to a Fieldbus device to prevent a short circuit on one spur from disabling the entire network segment. If a segment does not have galvanic isolation, current limiter protection can be defeated.

For example, suppose the minus wire is referenced to ground at the Fieldbus power supply and the cables shield is also grounded (as it should be). Normally, the current used by a device on the spur cable flows from the (+) wire, through the Fieldbus device and back on the negative wire through the current limiter. If the spur cable's (+) wire is accidentally shorted to the shield, the current no longer flows on the negative wire through the current limiter but on the shield directly to ground. Thus, the current limiter is bypassed and offers no short circuit protection.

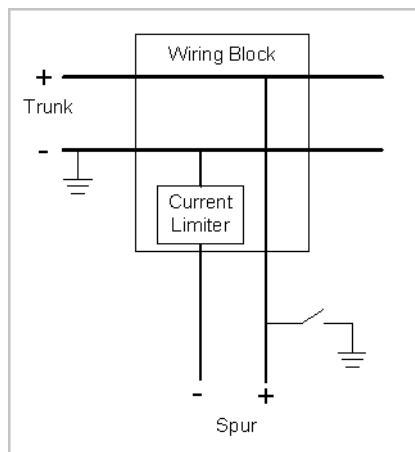

Figure 10.2: Bypassing the Current Limiter

A shield short to one of the network wires is a relatively common occurrence. When this happens on a network powered by a galvanically isolated Fieldbus power supply, the network still functions but with reduced noise immunity. Without galvanic isolation there is a possibility that current limiters will not work.

Crosstalk

Fieldbus network segments should be independent from each other. A power conditioner must have equal impedance on both wires of the segment or the segment must be galvanically isolated from all other segments. Without this, there is crosstalk between the two segments. "Crosstalk" means that signals on one segment partially appear on another segment. Crosstalk is caused by capacitive coupling between segment wires and the shield. This is a form of noise and makes network operation unreliable.

Multiple Wiring Errors

There must be segment independence such that a wiring error or wiring deterioration on one segment does not affect other segments. Consider the case where a galvanically isolated 24 V bulk power supply provides power to two Fieldbus power conditioners.

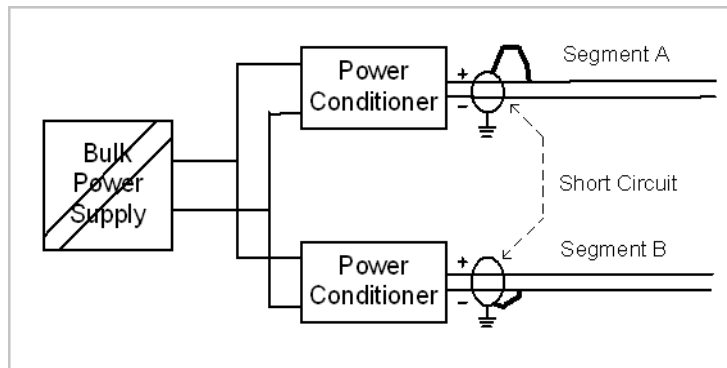

Figure 10.3: Common Isolator and Two Power Conditioners

Suppose segment A has its (+) wire shorted to the shield. This is not catastrophic. Segment A will continue to work with reduced noise immunity. Except for higher error rates on segment A, this condition may not be noticed. Now suppose that segment B's (-) wire is shorted to the shield. Now there is a short between the (+) wire of segment A and the (-) wire of segment B. This becomes a short circuit on both segments and disables both segments.

If galvanic isolation is used on each segment, they are completely independent. There is no crosstalk and wiring errors or wiring deterioration on one segment does not affect the other.

Isolation and Segment Independence

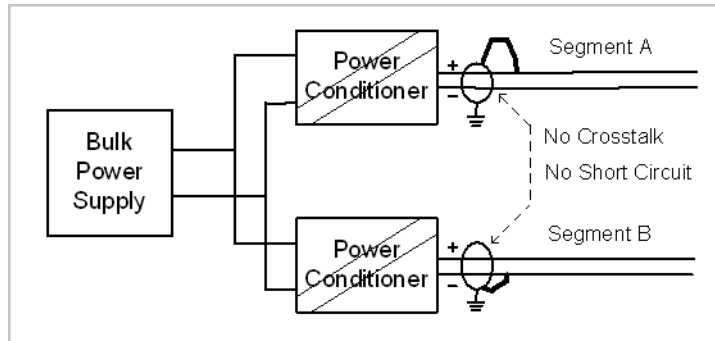

Figure 10.4: Individual Isolation

In short, galvanic isolation in each power conditioner provides the required isolation from ground and provides complete segment independence. The result is that a control system that is more reliable and robust.

Fieldbus Cable Selection and Installation for Process Plants

By Ian Verhappen

The wires inside a Fieldbus cable are the same regardless of cable jacketing type: two wires which are twisted with an overall shield covering them. The type of cable jacketing selected and how the cable is installed depends on a number of factors. A number of considerations relative to selection and installation of cables are summarized below.

Note: Always refer to the local electrical codes and regulations prior to installing any cable. This document is intended to provide a number of items that should be considered when selecting cable for Fieldbus installations but in no way replaces the requirement to have an electrical engineer or designer complete the final documentation used for construction.

Cable Types

As indicated above, the actual conductors in the cable must still adhere to the requirements of IEC61158 Part 2, in which the physical layer characteristics of the various types of Fieldbus cable are defined. All cables should have a minimum twist as specified in that country's electrical code and each successive layer shall be reversed in direction.

This twist minimizes the amount of "crosstalk" or internally generated interference between the signal on a single pair and in the case of multi-conductor cables, between the signal pairs. Individual cable shielding also helps reduce the effect of outside noise from the external environment as well as other wire pairs in the same overall cable jacket on signals.

All cables should have a tracer applied in a continuous spiral with a maximum lay of 2 inches (5 cm) so they can be easily identified at either end. In addition, all conductors should, and normally are, labeled with the same wire number at both ends. In many cases, the number is actually printed on the individual wire insulation.

There are basically two types of Fieldbus cables and the classification is largely determined by the type of jacket or outside overall protection on the cable. These two types of cable are:

- Ordinary jacket. This cable is normally wrapped with a flame retardant PVC coating
- Armored. (UL 1569 and UL 2225 for use in Division 1 and Zone 1)

Marine cables are a special subset of these two cable types with additional criteria for use in ships and boats. In the United States, marine cables are tested against Underwriters Laboratory (UL) standard UL 1309. All marine cables as defined by UL 1309 must also meet the requirements of IEEE Standard 45. Unarmored cable (UL 1246) has insulation and jacket. A jacket is only required if it is needed to protect the cable from contaminants and oil at 140° F (60° C) and below; it helps prevent the deterioration of the insulation and cable. Metal Clad cable is tested against the UL 1569 standard.

There are several different types of cables defined for use in industry. These are as follows:

- **Mineral Insulated (MI)** cable has a liquid and gas tight continuous copper sheath over its copper conductors and magnesium oxide insulation. MI cable may not be used where it is exposed to destructive corrosive conditions unless protected by materials such as PVC jacketing suitable for the conditions in which the cable is to be installed. MI cable is the most rigid type of cable available.
- **Metal Clad (MC)** cable is often used for feeder and branch circuit service. The cable has a metallic sheath that may be interlocking metal tape or a smooth or corrugated metal tube. A non-metal jacket is often extruded over the aluminum or steel sheath as a corrosion protection measure. For MC cables to be installed in Division 1 areas they must have a gas/vapor tight continuous corrugated aluminum sheath with a suitable plastic jacket over the sheath and must also contain equipment grounding conductors. In addition to the above requirement for classified areas listed termination fittings must be used where the cables enter equipment.
- **Tray Cable (TC)** is multi-conductor cable with a flame retardant nonmetallic sheath commonly used for power, lighting, control and signal circuits. This is the most commonly used cable and according to the United States National Electrical Code (NEC) it can be used for open wiring lengths of less than 50 feet (15 m) between the tray and the end device. The cable must be supported at distances not exceeding 6 feet (1.8 m) over this maximum 50-foot (15 m) distance.
- **Instrumentation Tray Cable (ITC)** is a type of Tray cable that has a nonmetallic jacket with a metallic shield or metallized foil shield with a drain wire enclosing the cables multiple conductors. ITC cable must comply with the crush and impact requirements of type MC cable and be clearly identified for its use. The number 22 AWG (American Wire Gauge) to number 12 AWG conductors that make up this cable are normally rated for 300 V. The relevant Underwriters Laboratory standard for ITC cable is UL 2250. UL 2250 requires ITC cable have a gas/vapor tight continuous sheath.

- **Power-Limited Tray Cable** is another multi-conductor cable but this time with a flame retardant nonmetallic sheath. Like ITC cable it has a metallic shield protecting its AWG 22 through 12 300-volt conductors.

Cable Support

All these cables require some form of mechanical support and protection so they can be run from point to point in a facility. There are basically four ways of supporting cable:

- Lashed to plant structural members
- Flexible conduit
- Rigid conduit
- Wire tray

The following table summarizes the environment by cable jacket type against the type of mechanical support recommended for its installation.

	A. Lashed to Structures	B. Flexible Conduit	C. Rigid Conduit	D. Wire Tray
Ordinary Jacket	X			X
Armored		X	X	
Marine Armored		X	X	

Installing cables within the guidelines presented above allows them to be installed in all electrical classification areas.

Fieldbus Cable

Fieldbus cables are referred to as trunks or home run cables and spurs or drops, the shorter cables that connect the end devices to the trunk. The individual conductor pairs of the trunk cable are normally connected to terminators at either end as well as the host system Input/Output card. The field end terminator is normally attached to the trunk rather than the farthest device so that it cannot be accidentally removed when a device is taken from service.

Most Fieldbus installations use a chicken foot or tree layout, which is well suited to the trunk, and spur arrangement since a multi-conductor cable is

used for the trunk to a field junction box from which individual wire pairs (spurs) are run to the specific end devices.

Despite the fact the above arrangement represents the vast majority of installations, especially as it is closest to normal installation practices, there are some cases where it makes more sense to use a bus topology with periodic spurs along a long trunk. In this situation a large multi-conductor cable does not make sense since the jacket integrity is broken at each connection to a spur and therefore a single wire pair (2 conductors + shield) or two pair (4 conductors + shield) cable would be used.

Additional considerations pertaining to the installation of Fieldbus cables are presented below as general comments, as well as conduit and cable tray installation recommendations.

Installation Considerations

Be aware of every Area Classification change and the associated electrical code requirements for glands and seals within prescribed distances from these boundaries. The rules may not be the same in all cases since there are different conditions in areas classified by Zones versus those classified by the Class / Division system. An example of this is the Canadian Electrical Code requires installation of seals within 450 mm (18") of the change in Division classification while the new code recognizes that if the cable installed across a change in Zone classification is more than 10 meters (33 feet) long and the hazardous gas concentration is less than 1.48% it is considered equivalent to a seal. In effect the liquid and gas tight composition of the cable provides the seal.

An IP67 seal works the same way as the cable just described by providing a gas tight seal around the cable thus preventing vapors or liquids from entering either the cable or device enclosure.

Intrinsically Safe (IS) wiring must be clearly identified and marked with permanent affixed labels. Most facilities accomplish part of this by having the foil sheath be a different color than other cables. The normally selected color for IS cables is a light blue.

When designing a cable system, consideration must also be given to the ambient conditions. Potential ice thicknesses to be used for design in the NEC are ½ inch for heavy loading, ¼ inch for medium loading, and no ice for light loading. The density of the ice is assumed to be 57 pounds/ft.³ (913kg/m³). Conversely the ice load on a round conduit will be less than that of a tray cable. Snow density is assumed to be 5 pounds/ft³ (80 kg/m³).

Most problems that occur involving instrumentation circuits are due to improper grounding practices. This can be prevented by following good installation practices, including insuring there are no possible routes for ground loops between any point in the cable and any other.

Many methods for sealing firewall penetrations are available including bag or pillow, caulk, cementitious foam, putty and mechanical barrier systems. The choice of which to use is site dependent.

Conduit

A separate ground wire shall be installed throughout each entire conduit run.

Large conduit banks require significant space, which is why most modern facilities are now using cable tray systems instead. Conduit banks also require more frequent and higher strength supports than cable tray. Rigid metal conduit must be at least 3 inches (75 cm) diameter to be supported on the 20 foot spans normally used in pipe racks.

Normal fill for conduit is 40% while for tray it is closer to 100%. This "spare" room is required to allow the cable to be pulled through fittings and bends in the conduit.

Conduit routes shall be kept away from high fire risk equipment and high temperature areas. If this is not possible MI stainless sheathed cables shall be used.

Liquid tight flexible conduit is to be used where movement and flexing are expected such as "end of run" applications. The last meter (3 feet) of the conduit run is normally completed with "flex." Based on plant practices this distance can be altered plus or minus a little bit.

Tray

80% of ladder cable tray sold has 9" rung spacing.

Cable trays containing electrical conductors cannot contain any other service that is not electrical.

No spacing is required between ITC and PLTC cables in a tray.

Since tray cables are circular the cable tray will have an irregular surface. Therefore the resulting ice load on a cable tray can be 1.5 to 2 times greater than the glaze ice load on a flat surface.

Though not required, many cable tray users separate the instrumentation cables from the power and control cables by installing them in separate cable trays or by installing as a minimum barriers in the tray. This is to prevent the harmonics and AC signals in the power and control cables from inducing voltage and current (noise) on the DC instrumentation cables.

Lengths of cable tray greater than 40 vertical feet are to be avoided to prevent undue stress at the upper bend. Vertical cables must be supported by the use of approved straps and other devices. Plastic tie downs are not

considered approved straps. Cable ties can be used to secure cable in horizontal tray runs.

The NEC states: "In a qualifying industrial installation, a conduit terminated on a cable tray may be supported from the cable tray. In a commercial or non-qualifying industrial installation, the conduit that is terminated on the cable tray must be securely fastened to a support that is within 3 feet (0.9 m) of the cable tray or securely fastened to a support that is within 5 feet of the cable tray where structural members don't readily permit a secure fastening within 3 feet. The conduit of the non-qualifying installation still needs to be bonded to the cable tray. A fitting may be used for this bonding even though it will not count as a mechanical support.

Over 99% of conduits supported on cable trays are the result of conduits being terminated on the cable tray side rails. For over 35 years it has been common practice to house the cables exiting the cable tray in conduits or cable channel where the distance from the cable tray system to the cable terminations requires the cable to be supported. The 1999 revision of the NEC now allows raceways, cables and outlet boxes as well as cable and conduit to be supported from cable trays. In addition a number of new products, known as tray baskets are available to protect and support cables between the tray and the end devices/equipment.

Marine Cable

The following portions of the United States Code of Federal Regulations (CFR) are relevant for installations in a marine environment as would be found on ships and boats.

(46 CFR Part 183.340) - Marine Cable and wiring requirements

- Individual wires greater than 50 volts must be installed in conduit.
- The use of tie wraps must be limited to bundling or retention of multiple cable installations and not used as a means of support.
- Conductors for direct current systems must be sized so that voltage drop at the load terminals does not exceed 10 percent.
- Armored cable metallic covering must be electrically continuous and be grounded at each end of the run.

(46 CFR Part 111.60) - Wiring Materials and Methods

- If a cable cannot pass the flammability tests of 111.60-2 it must be installed physically separate from all other cable and have fire stops installed at regular intervals, at each location a cable enters equipment, at each class boundary, and in a cableway with an A-60 fire rating.
- Metal Clad cable must be installed in accordance with Article 334 of the NEC.

Summary

In addition to the regulations specified in the local electrical code and regulations, some facilities may have practices above and beyond the minimum legislated requirements. This is simply another reason to work with a registered or licensed electrical professional familiar with the local needs. These professionals must as a minimum review any work before it is issued and built in the field.

References

More than 1,800 different governmental organizations in the United States, and several Latin American countries use National Fire Protection Association (NFPA) 7, commonly called the National Electrical Code® or the NEC® as the basis for the electrical regulations.

A new directive in Europe, ATEX applies to all installations of equipment and protective systems intended for use in potentially explosive atmospheres. A series of documents describing this directive can be found at <http://europa.eu.int/comm/enterprise/atex/guide>.

Other relevant standards organizations include (If viewing this document in pdf format, click on the URL to open the page in a web browser):

Institute of Electrical and Electronic Engineers (IEEE), www.ieee.org

Underwriters Laboratories (UL), www.ulstandardsinfont.ul.com or www.ul.com

U.S. Occupational Safety and Health Administration (OSHA), www.osha.gov

National Electrical Manufacturers Association (NEMA), www.nema.org

Canadian Standards Association (CSA), www.csa-international.org or www.csa.ca

Electrical and Electronic Manufacturers' Association of Canada (EEMAC), www.electrofed.com

British Standards Institute (BSI), www.bsi.org

International Electrotechnical Committee (IEC), www.iec.ch

American National Standards Institute (ANSI), www.ansi.org

National Standards System Network (NSSN), www.nssn.org

European Committee for Electrotechnical Standardization (CENELEC) www.cenelec.org

Hazardous Area Power and Repeaters

Summary: Limited Fieldbus power can be sent into hazardous areas using FISCO power supplies. By using repeaters, a number of power limited segments can be combined to look like one segment to the H1 host controller.

Fieldbus devices used in **hazardous areas** can be supplied with a limited amount of power. Using traditional **barriers**, only about three Fieldbus devices can be on a segment. A new Fieldbus powering method called FISCO (Fieldbus Intrinsic Safety Concept) increases the available power to where about five devices can be on a segment. This still presents a problem.

A process to be controlled may require more devices to work together. A way to do this is to have the H1 host controller relay messages between devices on independent segments. This is problematic because an H1 host controller only has a limited number of Fieldbus connections ports. Repeaters can be used to solve the power limitation problem.

Repeaters are devices that interconnect Fieldbus segments into a single network. A repeater takes signals from one segment, reconstructs them to the proper waveshape and retransmits them on to the other segment. The devices on the separate segments think they are on the same segment. Fieldbus power must be separately provided to each segment.

Repeaters can be used to extend the length of a Fieldbus network. This is not generally necessary. See "*Fieldbus Limitations*" on page 19. Repeaters are more useful in hazardous area applications to combine electrically separate segments to look like a single logical segment. The example below shows this arrangement. Note that each segment require a pair of terminators. Repeaters often have terminators as part of their assembly.

Hazardous Area Power and Repeaters

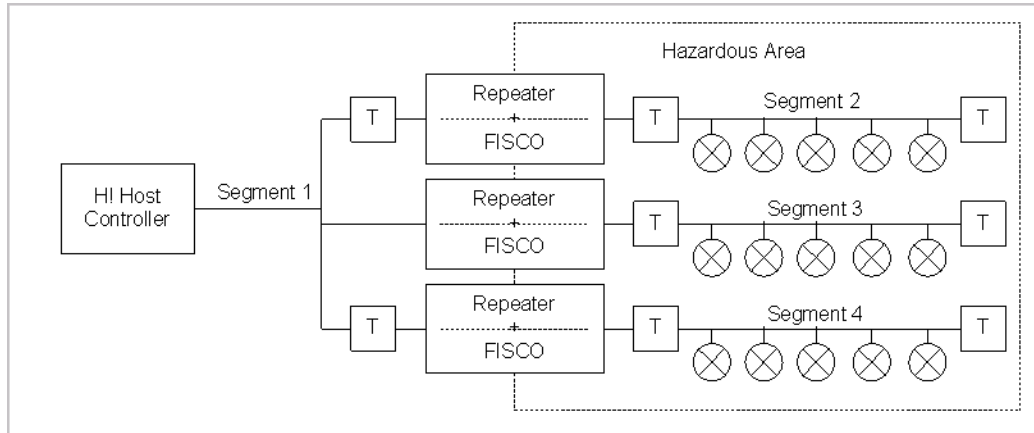

Figure 12.1: Repeaters with FISCO Power Supplies

Suppose Fieldbus segments 2, 3, and 4 are in a hazardous area. Each segment has 5 devices that need to communicate with each other and with devices on the other segments. Three repeaters with built-in FISCO power supplies are used as shown. All the data packets sent by any one of the Fieldbus devices appear on all segments including segment 1. The H1 host controller needs to have only one Fieldbus port. To the host and to each of the devices, data transmission and reception appears to be on a single network. In reality, they are on separate physical segments. Each segment is individually powered and terminated in the same way as any other Fieldbus segment.

Current Limiters for Nonincendive Protection

Summary: If current limiters are used on spur connections from the wiring block, the connected Fieldbus devices in a Div 2 or Zone 2 area can be live-worked without permits.

Besides protecting a network from a short circuit on a spur from disabling the whole network, current limiters provide another benefit. They permit a Fieldbus device to be connected or disconnected from a network in a hazardous area without:

- Turning off the power to the network or
- Having to determine by sniffing if the area is safe.

This is only applicable to Div 2 or Zone 2 areas and only in places that recognize the nonincendive protection method (not Canada). The requirements for nonincendive protection are defined in ISA standard 12.12.01-2000. There are four requirements:

- 1 Nonincendive field wiring needs to be provided. This means that under normal operating conditions of the equipment, the wiring is not capable of producing an ignition. Normal operation includes opening, shorting or grounding of the wiring.
- 2 The Fieldbus device powered from a current limited wiring block output needs to be nonincendive. This means the electrical energy stored by the device that can be dissipated outside the device under normal operating conditions needs to be limited. Normal operation includes opening, shorting or grounding of the field wiring.
- 3 The spur cable used to connect the Fieldbus device to the wiring block output may not store enough energy to cause an ignition.
- 4 The temperature in the Fieldbus device must not exceed a specified value. This is given by the device's temperature rating number.

Because a bus-powered Fieldbus device does not generate electrical energy, only the energy storing components in the device need to be considered. These are capacitors and inductors that can be discharged into the spur cable. The maximum value of these energy-storing components C_a and L_a have been determined for safe operation.

Current Limiters for Nonincendive Protection

Gas Groups	A, C (IIC)	C (IIB)	D (IIA)
C_a	170 nF	1.22 μ F	4.59 μ F
L_a	1.2 mH	3.4 mH	6.3 mH

The capacitance and inductance of the spur cable also have to be considered. Standard Fieldbus cable capacitance is 0.15 nF/m while inductance is 0.54 μ H/ m. A representative Fieldbus cable 120 meters long (the longest suggested spur length) has a capacitance of 24 nF and an inductance of 65 μ H.

The capacitance and inductance of the Fieldbus device must also be considered. A representative value for Fieldbus device's capacitance is 5 nF. A representative value for Fieldbus device's inductance is 10 μ H.

Adding the cable and device capacitances and inductances together yields 29 nF and 75 μ H. Thus, for normal Fieldbus device operation on the longest spur cable, the values of the energy storing components are well below the safe operation requirements shown in the table above.

Fieldbus devices intended to operate in hazardous areas have a temperature rating, which is determined from the maximum surface temperature of components that are exposed to the flammable hazard. For nonincendive circuits, a T4 rating is usually easily achieved, since the analysis considers only the maximum temperature in normal operation.

Although safety parameter values for voltage, current and power are sometimes published for nonincendive field wiring and field devices, the matching of current and power in nonincendive circuits is not required by ISA standard 12.12.01-2000. For a field device that controls its own current consumption, such as a Fieldbus instrument, the only requirement is to match the maximum output voltage of the spur connection with the maximum safety input voltage of the device. In normal operation, the field device cannot by definition draw more current or consume more power than its published operating values, although higher values may be available from the Fieldbus wiring.

Note: Wiring blocks may not be connected to or disconnected from the trunk cable without determining that the area is safe or without turning off the power to network.

Earthing/Grounding Guidelines

By MTL

FOUNDATION™ Fieldbus Requirements

Clause 6.3.3 of the FOUNDATION™ fieldbus System Engineering Guidelines AG-181, Revision 2.0 states the preference for a single point of earthing in a fieldbus network:

“Network cable shields shall be earthed/grounded at one location only, at the field termination assembly (host) end. At a field instrument, the cable shield shall not be connected to the instrument earth/ground or chassis.”

In addition, AG-181 recognize that capacitors may be connected to ground at the field device or field junction box ‘to avoid build-up of DC and reduce EMI’.^{Note 1}

Possible earthing/grounding arrangements for fieldbus systems are also described in Clause 4.4 of FOUNDATION™ Fieldbus Application Guide AG-163, Revision 2.0. Among the methods given are: single-point earthing in the non-hazardous area, multiple-point earthing with potential equalization, and a combination of single-point earthing with multiple capacitors connected to earth in the field.

Hazardous Area Considerations

Guidance on earthing/grounding of instrumentation circuits in hazardous areas is found in IEC60079-14: 2002 (“Electrical apparatus for explosive gas atmospheres, Part 14: Electrical installations in hazardous areas”). Clause 12.2.2.3 “Earthing of conducting screens” may be summarized as follows:

- Where a cable screen is required, it shall be connected to earth at one point only, normally at the non-hazardous area end of the circuit.
- If ‘potential equalization’ is known to exist between the ends of the circuit, then cable screens may be connected to earth at both ends of the cable.
- Multiple earthing through small capacitors (for example 1nF, 1,500V ceramic) is acceptable provided that the total capacitance does not exceed 10nF.

Separate earthing of sub-circuits that are galvanically isolated from each other is permitted.

Practical Earthing/Grounding Arrangements

Acceptable earthing arrangements for fieldbus installations using *Megablock* wiring components and MTL-Relcom power supplies for general purpose installations must comply with FOUNDATION™ Fieldbus requirements. Three possible options are described, as follows:

Single point of grounding at fieldbus power supply

Figure 14.1 shows the preferred arrangement, where:

- The trunk cable shield is grounded at the fieldbus power supply and connected at the wiring block inside the to the fieldbus junction box. With Megablock wiring hubs, the shield should be connected to the 'S' terminal of the trunk (black) connector.
- The spur cable shields are connected at the wiring block inside the fieldbus junction box and left unconnected at the fieldbus device. Care **must** be taken to prevent accidental contact of the shield with the device case. With Megablock wiring hubs, the shield should be connected to the 'S' terminal of the spur (grey) connector.
- There is continuity between the trunk and spur cable shields (as provided internally inside the Megablock).
- No connection is made between the trunk or spur cable shields and the fieldbus junction box.

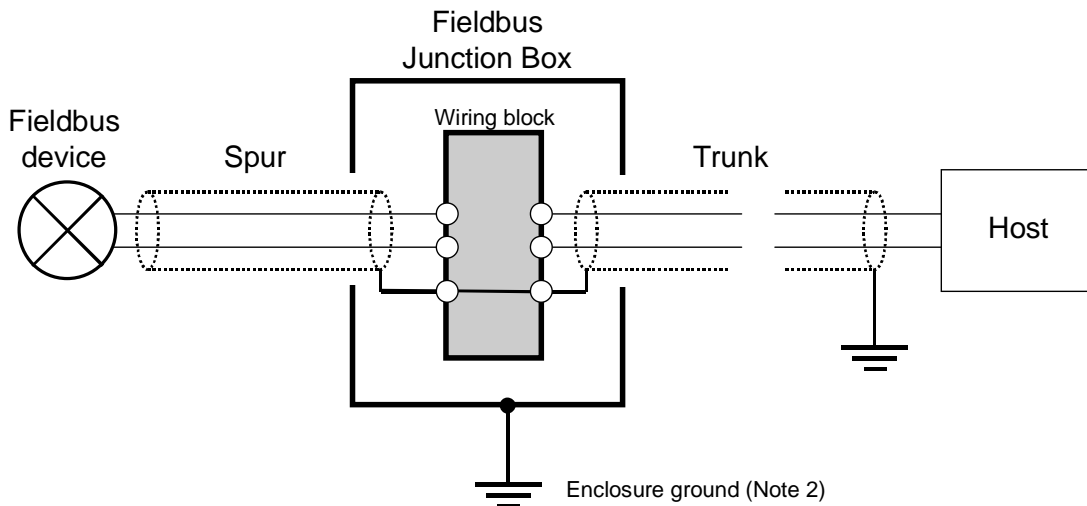

Figure 14.1: Preferred earthing arrangement

Capacitive Grounding of Spur Cables

Figure 14.2 shows the preferred arrangement, where:

- The trunk cable shield is grounded at the fieldbus power supply and connected at the wiring block inside the to the fieldbus junction box. With Megablock wiring hubs, the shield should be connected to the 'S' terminal of the trunk (black) connector.
- The spur cable shields are connected at the wiring block inside the fieldbus junction box. With Megablock wiring hubs, the shield should be connected to the 'S' terminal of the spur (grey) connector.
- A capacitor is connected from the cable shield to ground inside each fieldbus device.
- There is continuity between the trunk and spur cable shields (as provided internally inside the Megablock).

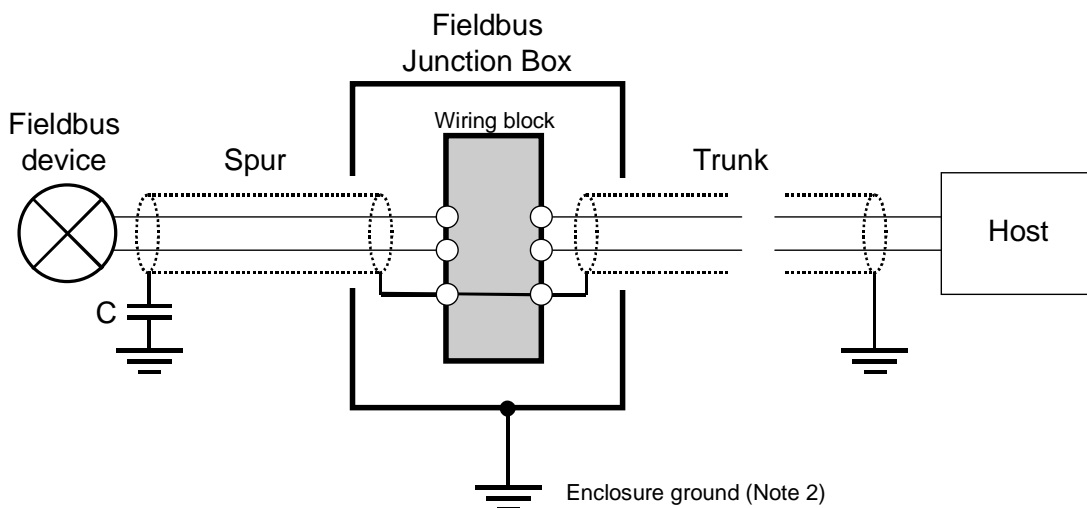

Figure 14.2: Alternative earthing arrangement for improved EMC performance

Multiple grounding with potential equalization

Where the plant metalwork is known to be securely bonded together throughout the length of the fieldbus segment, such that significant potential differences cannot occur at different points, an 'equipotential' plane may be assumed. The cable shields of the trunk and spur cables may therefore be grounded at multiple points, as shown in Figure 14.3.

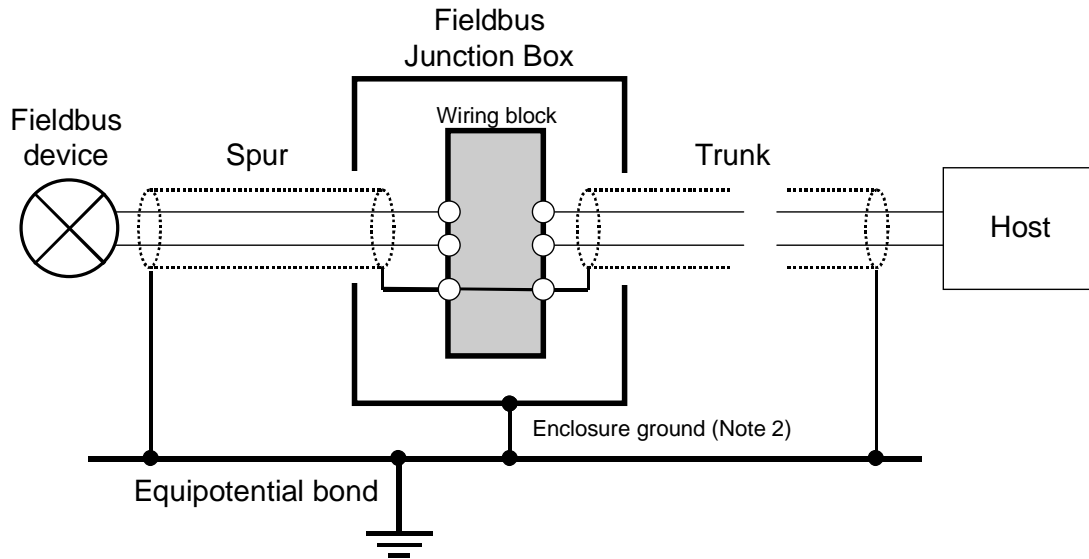

Figure 14.3: Multiple grounding with potential equalization

Notes

1. Normally a high-value resistor, such as 100k Ω , would be connected in parallel with the capacitor to provide a DC reference. The diagram in Clause 6.3.3 of AG-181 is misleading because it shows the capacitor connector to one side of the fieldbus circuit instead of to the cable shield.
2. Metal junction boxes should be connected to local plant metalwork. An earth stud is usually provided for this purpose. Non-metal enclosures such as Glass Reinforced Polyester do not require a local protective earth, but where possible anti-static bonding should be provided by mounting onto earthed metalwork.
3. If the fieldbus cable is protected by steel wire armor, it is normal practice for the armor to be electrically connected to local plant metalwork at each end. This is normally accomplished using suitable cable glands to provide continuity between the armor and the enclosure or gland plate. Non-metal fieldbus junction boxes, such as MTL's FCS-8000 Series have a steel gland plate and separate earth stud for local earthing of cable armors.

Glossary

Term	Definition
Attenuation	A signal getting smaller as it travels on the cable
Barrier	A device for interconnecting circuits between a safe area and a hazardous area that prevents electrical power from the safe area causing an ignition in the hazardous area
Bit Cell	The time duration for one digital bit in the signal
Cable	Signals wires, shield, and covering jacket
Chickenfoot	A common distribution point for spur cables, usually a junction box
Drop Cable	A cable between the trunk cable and a Fieldbus device. Also called "Spur"
End Delimiter	A data pattern that signals the end of the data in a frame
Frame Check Sequence (FCS)	A code generated by a transmitting device and sent along with the data that is used by the receiving device to determine if the received data is uncorrupted
H1	The device in the control room that controls or monitors the Fieldbus network. Also called "Host"
Hazardous Area	A place where vapors or gasses exist such that they can ignite or explode
Home Run	The main cable between the control room and a junction box in the field. Also called "Trunk"
Host	The device in the control room that controls or monitors the Fieldbus network. Also called "H1"
Link Active Scheduler (LAS)	A device that tells other devices on the network when they are allowed to transmit
Manchester	A data encoding method used for Fieldbus signals
NEC	United States National Electrical Code

Power Conditioner	The filter between a power supply and Fieldbus wiring
Preamble	The first part of a data frame
Segment	A Fieldbus network that is separately powered and has its own terminators
Spur	A cable between the trunk cable and a Fieldbus device. Also called "Drop"
Start Delimiter	A data pattern that signals the start of data part of a frame
Terminator	A device on a segment that shapes the transmitted signals and prevents signal distortion
Trunk Cable	The main cable between control room and a junction box in the field. Also called "Home Run"
Twisted Pair	Two wires twisted together for noise cancellations purposes

Further Information

MTL Application Notes

The following application notes are available from your local MTL contact, or visit www.mtl-fieldbus.com.

- MTL Application Note AN9026 FISCO Intrinsically Safe Fieldbus Systems
- MTL Application Note AN9027 FNICO Non-Incendive Fieldbus Systems

MTL Contacts

Contacts listed in alphabetical order by country.

MTL Instruments Pty Limited
9 Vinnicombe Drive
PO Box 1441, Canning Vale,
Perth, WA 6155
Australia

Tel: +61 (0)8 9455 2994 Fax: +61 (0)8 9455 2805
E-mail: enquiries@mtlaus.com.au

MTL Canada Safety Instrumentation
20 Regan Road, Unit 17
Brampton, Ontario L7A 1C3
Canada

Tel: +1 905 840 7850 Fax: +1 905 840 7852
E-mail: cinfo@mtlnh.com

MTL Instruments (Beijing)
Room 07-05A, The Gateway
No 10 Yabao Road, Chaoyang District
Beijing 100020
China

Tel: +86 010 8562 5718, 5720, 5721 Fax: +86 010 8562 5725
E-mail: bjsales@mtlsing.com.sg

MTL Instruments sarl
âtiment 4,
Parc d'Activités de Limonest
1 rue des Vergers
69760 Limonest
France

Tel: +33 (0)4 78 64 98 32 Fax: +33 (0)4 78 35 79 41
E-mail: info@mtl-inst.fr

MTL Instruments GmbH
An der Gumpgesbrücke 17
D-41564 Kaarst
Germany

Tel: +49 (0)2131 718930 Fax: +49 (0)2131 7189333
E-mail: info@mtl.de

MTL India Private Limited
No. 36, Nehru Street,
Off Old Mahabalipuram Road
Sholinganallur,
Chennai - 600 119
India

Tel: + 91 (0)44 24501660/24501857 Fax: + 91 (0)44 24501463
E-mail: sales@mtlindia.com

MTL Italia srl
Via Fosse Ardeatine, 4
I - 20092 Cinisello Balsamo MI
Italy

Tel: +39 (0)2 61802011
Fax: +39 (0)2 61294560
E-mail: info@mtl-inst.it

MTL Instruments KK
3rd Floor, Gotanda Masujima Building
1-8-13 Higashi-Gotanda, Shinagawa-Ku
Tokyo 141-0022
Japan

Tel: +81 (0)3 5420 1281
Fax: +81 (0)3 5420 2405
E-mail: sales@mtlkk.co.jp

MTL Instruments BV
de Houtakker 33, 6681 CW Bommel
The Netherlands

Tel: +31 (0)48 1450250 Fax: +31 (0)48 1450260
E-mail: info@mtlbenelux.com

MTL Instruments Pte Limited
128 Joo Seng Road
#07-00 DP Computers Building
Singapore 368356

Tel: +65 6 487 7887 Fax: +65 6 487 7997
E-mail: sales@mtlsing.com.sg

MTL Instruments
Abu Dhabi Mall, The Towers at the Trade Centre,
West Wing - 8th Floor
PO Box #53234
Abu Dhabi, UAE

Tel: +971 2 645 2620 Fax: +971 2 645 2630
E-mail: mtlgulf@mtl-inst.com

MTL Instruments Limited
Power Court, Luton, Bedfordshire
England LU1 3JJ

Tel: +44 (0)1582 723633 Fax: +44 (0)1582 422283
E-mail: enquiry@mtl-inst.com

MTL Incorporated
9 Merrill Industrial Drive, Hampton NH 03842
USA

Tel: +1 800 835 7075, +1 603 926 0090
Fax: +1 603 926 1899
E-mail: info@mtlnh.com



Fieldbus

Wiring Guide

USA \$20

07/04

Relcom, Inc.

2221 Yew Street

Forest Grove, OR 97116

t : 503-357-5607

800-382-3765

f : 503-357-0491

fieldbus@relcominc.com

relcominc.com